

Activities in Euratom projects SAMOFAR and SAMOSAFER

Jan Leen Kloosterman
Delft University of Technology
on behalf of all partners in the projects



SAMOFAR

2015-2019



2019-2023

History of Euratom projects

- ▶ MOST aiming at the recovery of data and simulation tools for thermal reactor designs focusing on validation with historic data from the MSRE.
- ▶ ALISIA resulting in the selection of the fuel salt and design choices for a European MSR.
- ▶ EVOL focusing on design of the Molten Salt Fast Reactor (MSFR), which is now the EU Gen-IV reactor.
- ▶ SAMOFAR focusing on the safety analysis of the MSFR and further development of the reactor design. Several experimental setups were designed and constructed, like SWATH-S and DYNASTY.
- ▶ SAMOSAFER expanding the experience and knowledge from previous projects with the aim to ensure that MSR technology can fully comply with the more stringent safety requirements expected in 30 years time.

SAMOFAR: Partners

Number	Organisation	Country
1	Technische Universiteit Delft (TU Delft)	Netherlands
2	Centre National de la Recherche Scientifique (CNRS)	France
3	JRC – Joint Research Centre– European Commission (JRC)	Germany
4	Consorzio Interuniversitario Nazionale per la Ricerca Tecnologica Nucleare (CIRTEN)	Italy
5	Institut de Radioprotection et de Sûreté Nucléaire (IRSN)	France
6	Centro de Investigaciony de Estudios Avanzados del Instituto Politecnico Nacional (CINVESTAV)	Mexico
7	AREVA NP SAS (AREVA)	France
8	Commissariat a l’Energie Atomique et aux Energies Alternatives (CEA)	France
9	Electricité de France S.A. (EDF)	France
10	Paul Scherrer Institute (PSI)	Switzerland
11	Karlsruher Institut für Technologie (KIT)	Germany

Aim of the project

- ▶ The grand objective of SAMOFAR was to:
 - prove the innovative safety concepts of the MSFR,
 - deliver breakthrough in nuclear safety and waste management
 - create a consortium of stakeholders beyond SAMOFAR

- ▶ Main results are:
 - experimental proof of concept
 - (integral) safety assessment of the MSFR
 - update of the conceptual design of the MSFR
 - roadmap and momentum among stakeholders

WP1: Reference design MSFR

Thermal power	3000 MWth
Mean fuel salt temperature	725 °C
Fuel salt temperature rise in the core	100 °C
Fuel molten salt - Initial composition	LiF-ThF₄-UF₄ (77.5-20-2.5 mol%) LiF-ThF₄-UF₄-(TRU)F₃ with (77.5-6.6-12.3-3.6 mol%)
Fuel salt melting point	585 °C
Fuel salt density	4.1 g/cm³
Fuel salt dilation coefficient	8.82 10⁻⁴ / °C
Fertile blanket salt - Initial composition	LiF-ThF₄ (77.5%-22.5%)
Breeding ratio (steady-state)	1.1
Total feedback coefficient	-5 to -8 pcm/K
Core dimensions	Diameter: 2.26 m Height: 2.26 m
Fuel salt volume	18 m³ (50% in the core)
Blanket salt volume	7.3 m³
Total fuel salt cycle	3.9 s

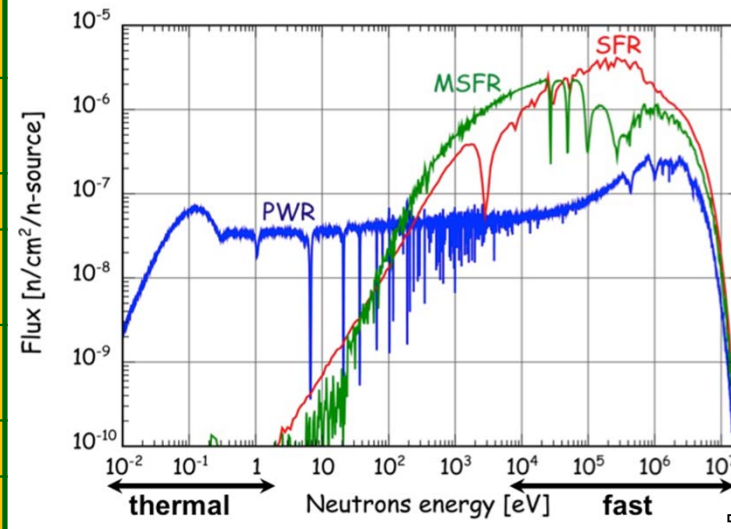
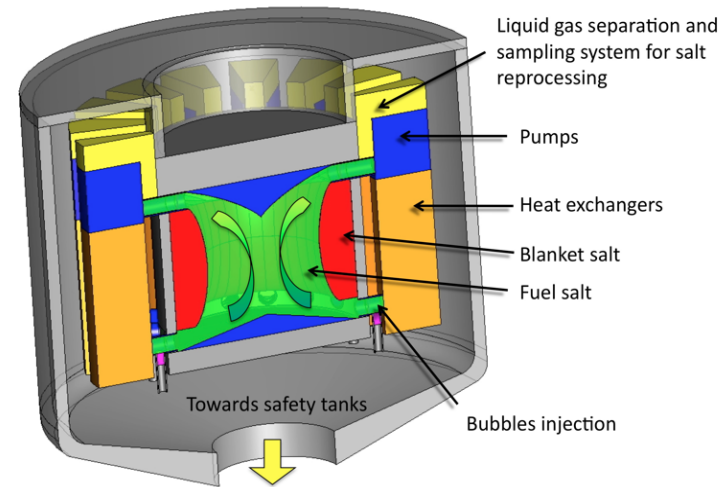

WP1: Integral safety assessment

- ▶ Development of a power plant simulator
- ▶ Dynamic behaviour of MSFR including startup, shut-down, control, load-follow operation
- ▶ Development of an integral safety assessment methodology (MLD-FFMEA → PIE → LOD)
- ▶ Risk assessment based on integral safety method
- ▶ Proliferation aspects
- ▶ ...



WP1 : Simulator

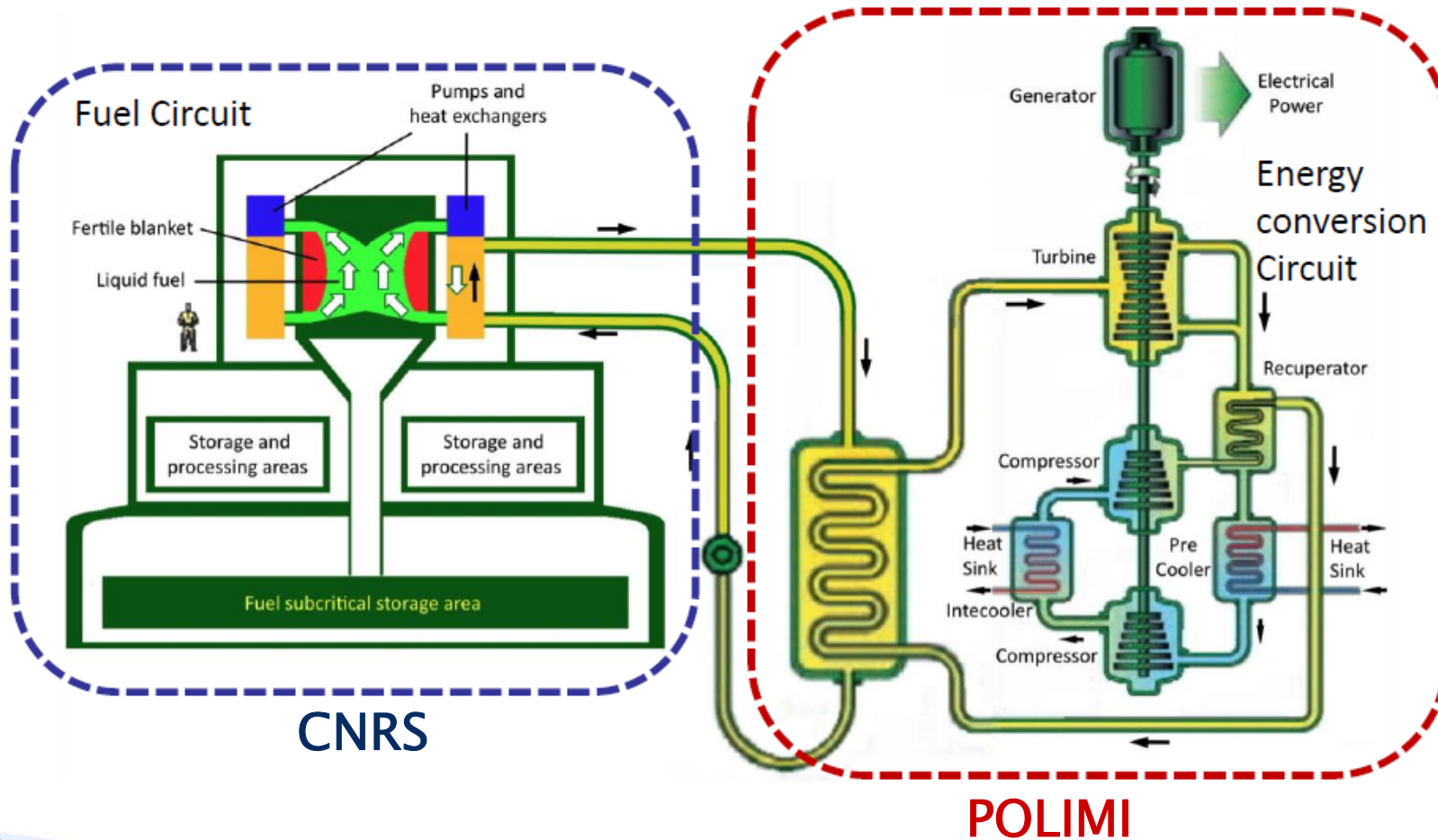

WP1 : Simulator (LiCore Code)

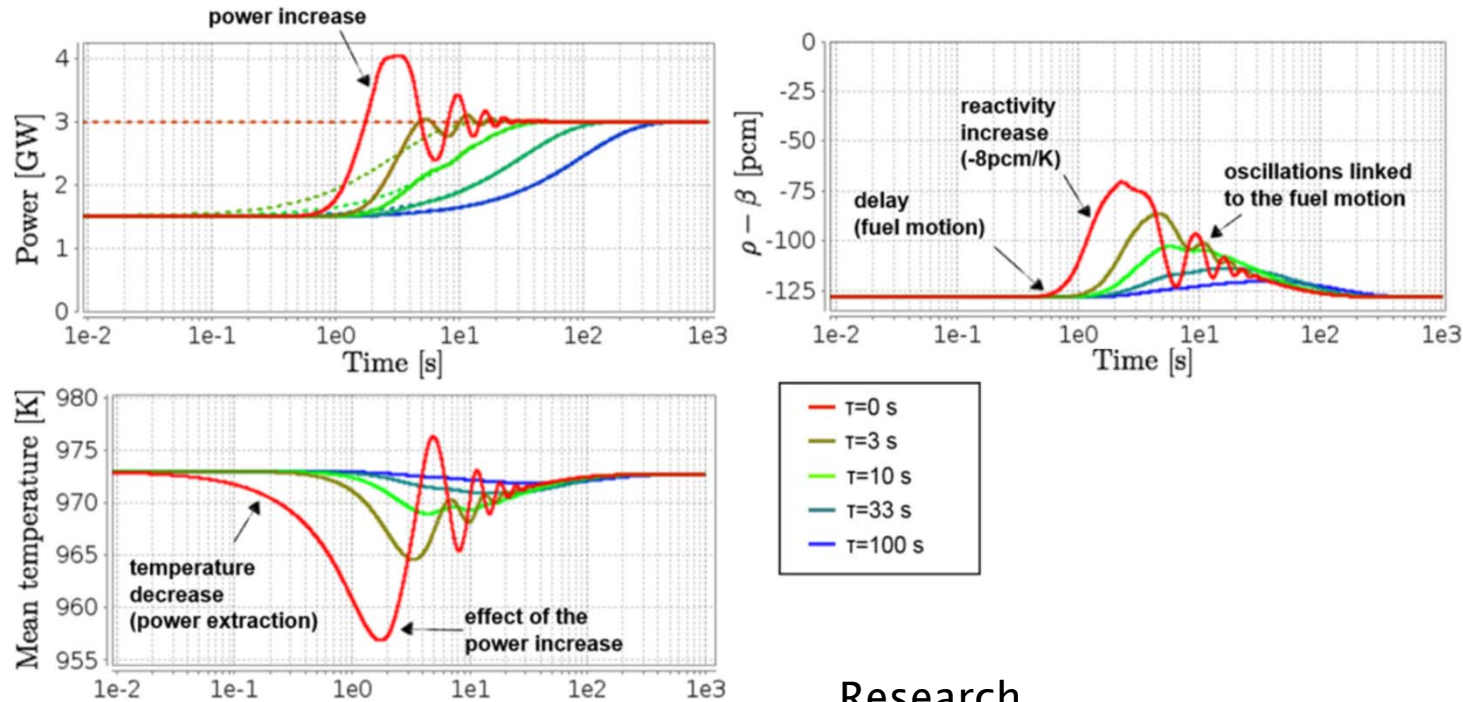

Research

- Dynamic behaviour of MSFR
- Reactor control strategies
- Operation procedures (full power, startup, shutdown, etc)

WP2: Safety related data

- ▶ Synthesis of salts containing PuF_3 and UF_4
- ▶ Measurement of phase diagrams of fuel salts
- ▶ Development of experimental techniques and measurement of thermal properties of fuel salts
- ▶ Examining precipitates upon super-cooling
- ▶ Examining FP release upon super-heating (up to vaporization)
- ▶ Interaction of fuel salt with water under irradiation
- ▶ Measurement of retention properties Iodine and Cesium
- ▶ ...

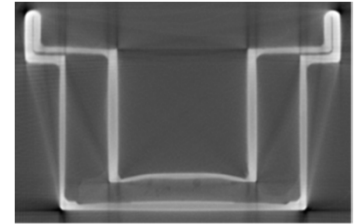

WP2: Synthesis of salts



WP3: Experimental validation

- ▶ Natural circulation dynamics of fuel salts with internal heating
- ▶ Measurement of natural circulation stability maps
- ▶ Physical condition of fuel salt during draining
- ▶ Freeze plug design and salt draining dynamics
- ▶ Measurement of solidification phenomena along walls
- ▶ ...

WP3: SWATH-S facility

Global performance :

- Salt : FLiNaK
- Total volume : 50 l
- Service temperature range : 550°C => 700°C

Velocity (m/s) 20 mm inner pipe diameter	Flow rate (l/min)	Time (minutes)
0.1	1.88	26.5
0.3	5.65	8.8
0.5	9.42	5.3

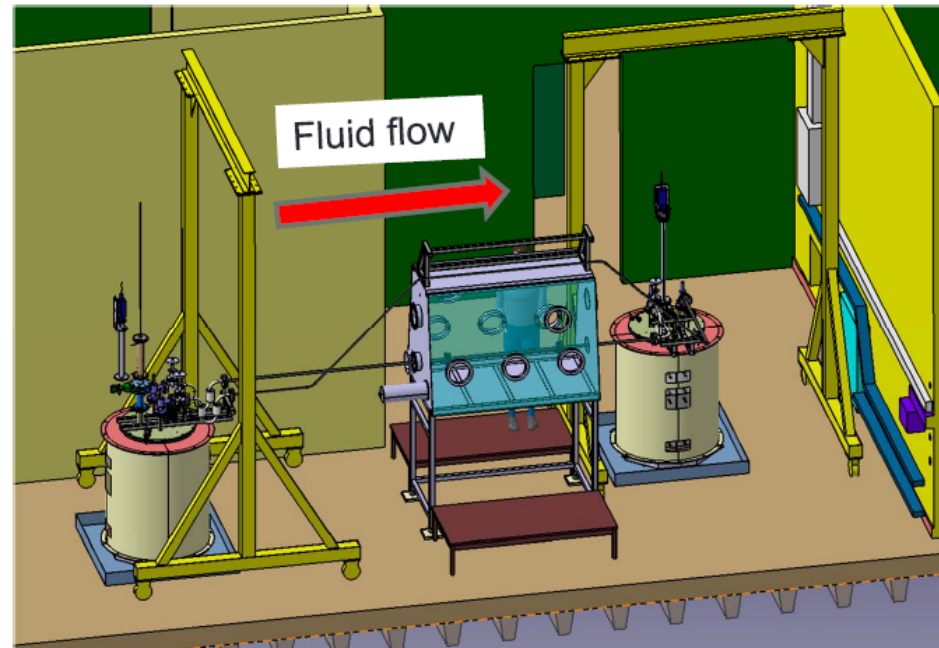

WP3: Dynasty facility

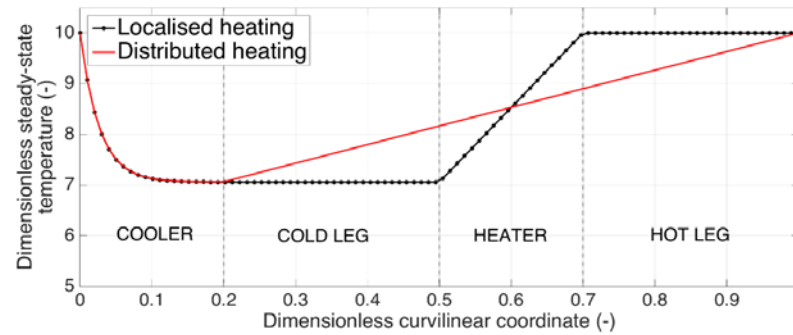
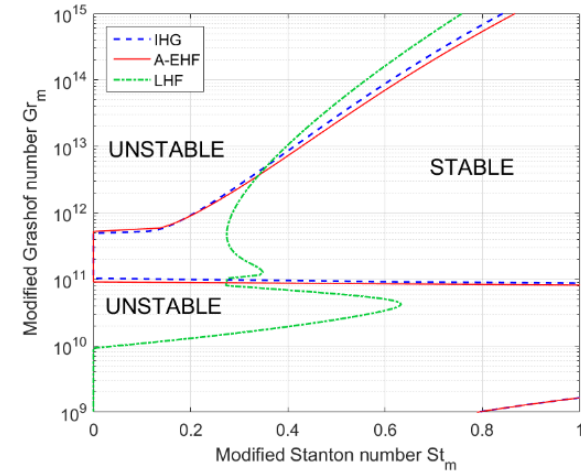
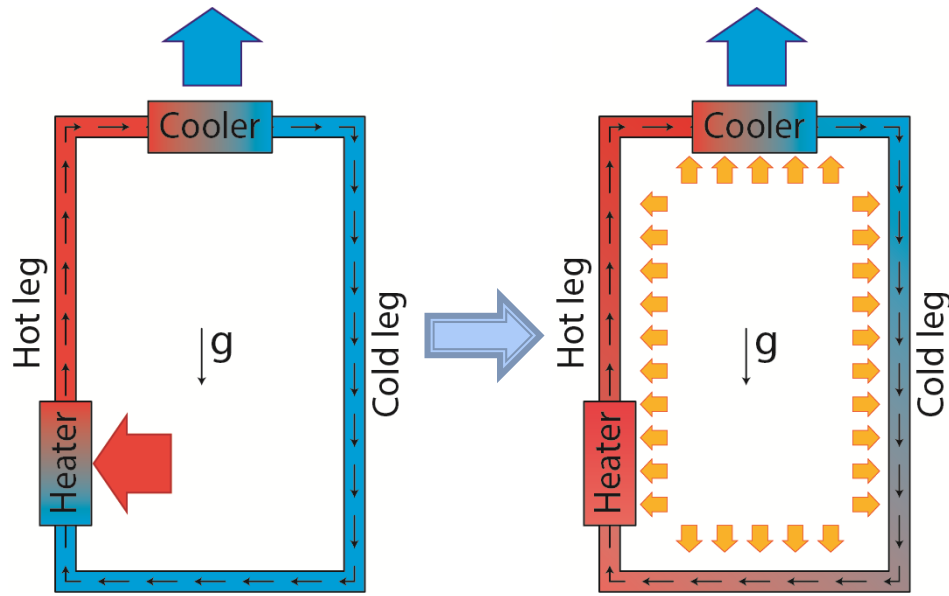

WP3: eDYNASTY coupled facility

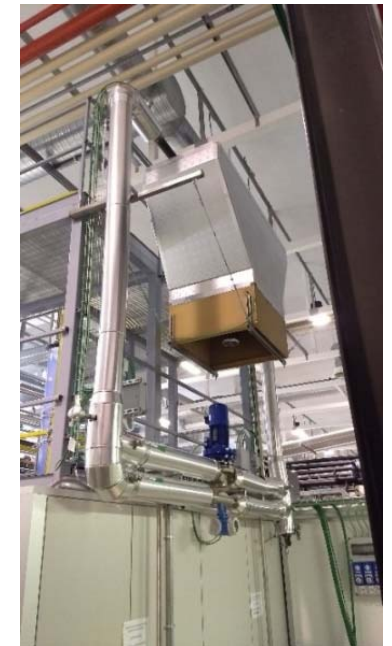
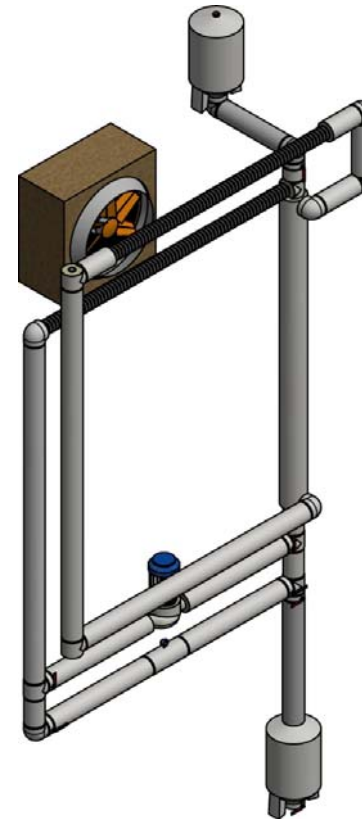
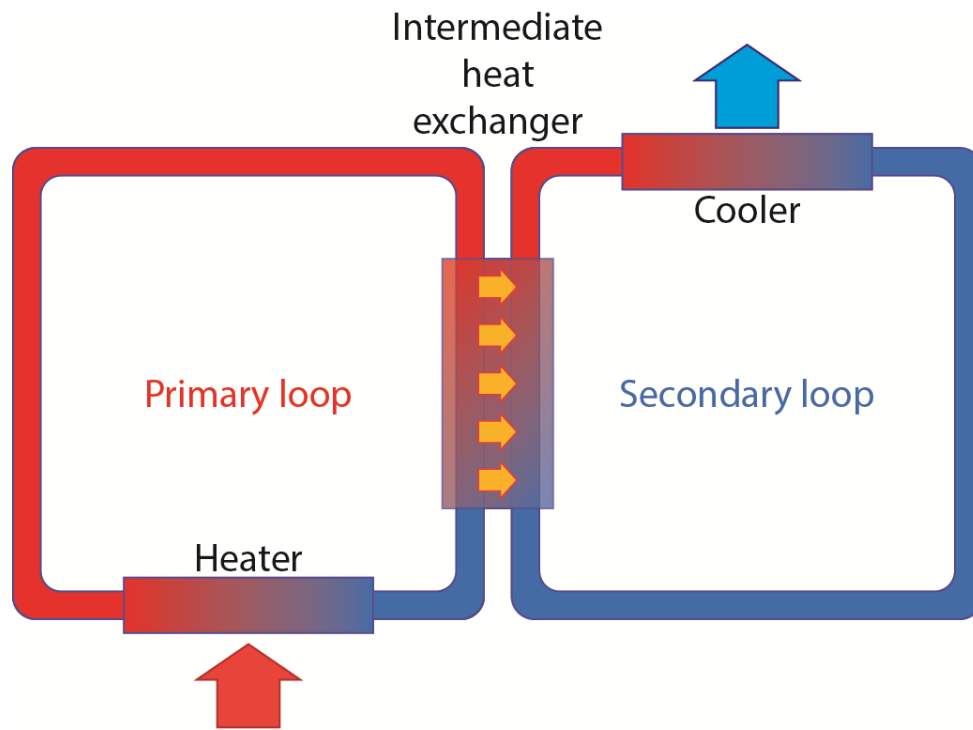

WP4: Numerical assessment

- ▶ Multi-physics simulation tools based on leading edge neutron transport and CFD methods including uncertainty propagation
- ▶ Transient analysis as identified in WP1 (normal operation and off-normal operation)
- ▶ Decay heat removal via natural circulation
- ▶ Thermal expansion reactor vessel
- ▶ Salt draining simulations
- ▶ ...

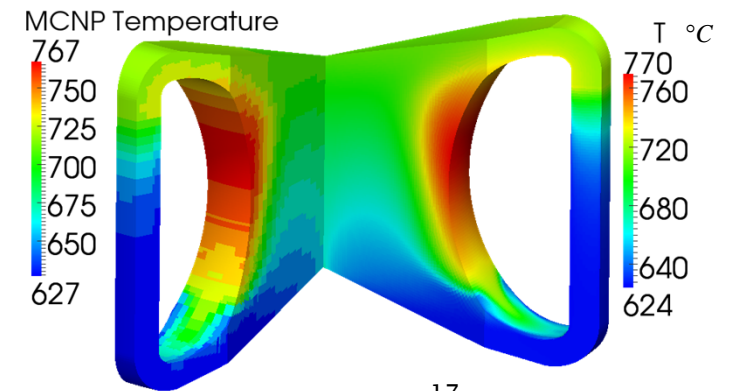

WP4: ULOFF in MSFR

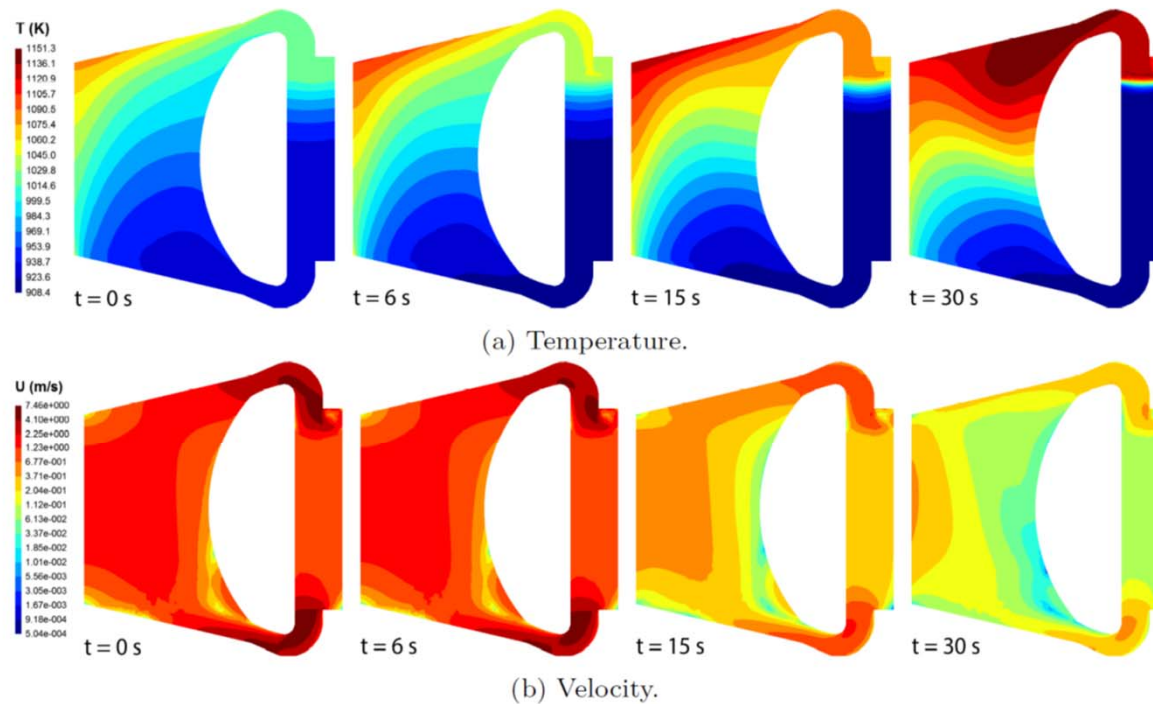
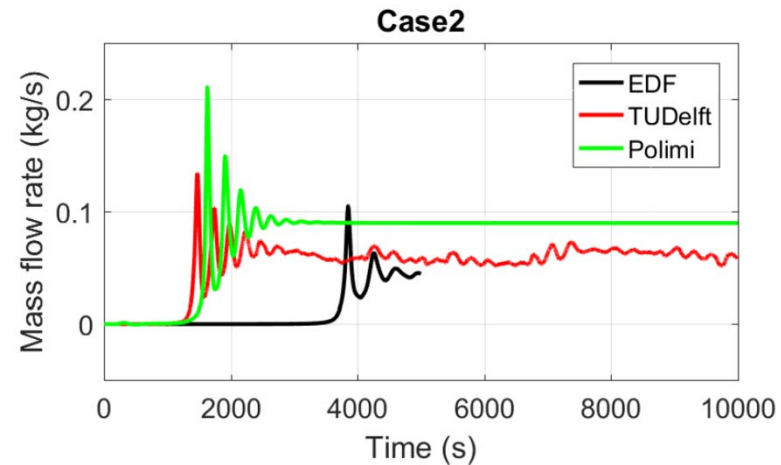
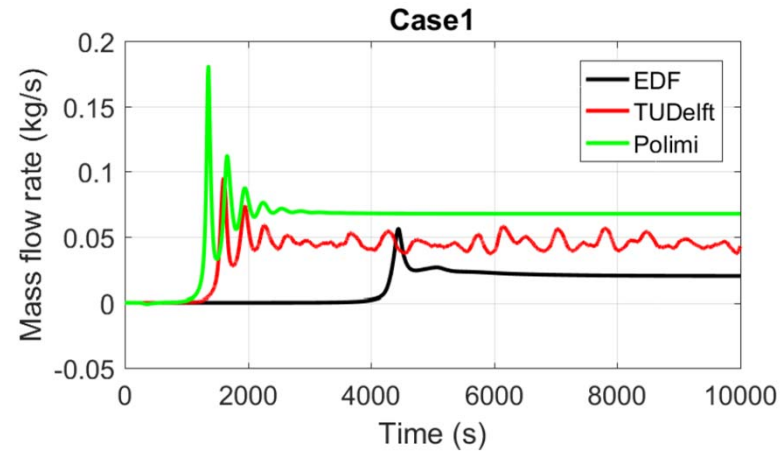
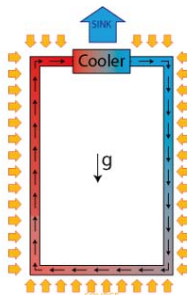

Fig. 5.14. ULOFF: evolution of the distributions of temperature and velocity along the reactor vertical mid-plane. The latter plot uses a logarithmic scale to magnify the low velocity magnitudes at the end of the transient.

WP4: Dynamics of natural circulation loops

Experiments to be run		
Experiment	Power	T_{cooler}
1	0.5 kW	180 °C
2	0.75 kW	190 °C
3	0.75 kW	210 °C
4	0.75 kW	250 °C
5	1 kW	180 °C
6	1 kW	200 °C
7	1 kW	240 °C
8	5 kW	180 °C
9	5.3 kW	190 °C
10	5.3 kW	240 °C



WP4: Dynamics of natural circulation loops

Experiments to be run		
Experiment	Power	T_{cooler}
1	0.5 kW	180 °C
2	0.75 kW	190 °C
3	0.75 kW	210 °C
4	0.75 kW	250 °C
5	1 kW	180 °C
6	1 kW	200 °C
7	1 kW	240 °C
8	5 kW	180 °C
9	5.3 kW	190 °C
10	5.3 kW	240 °C

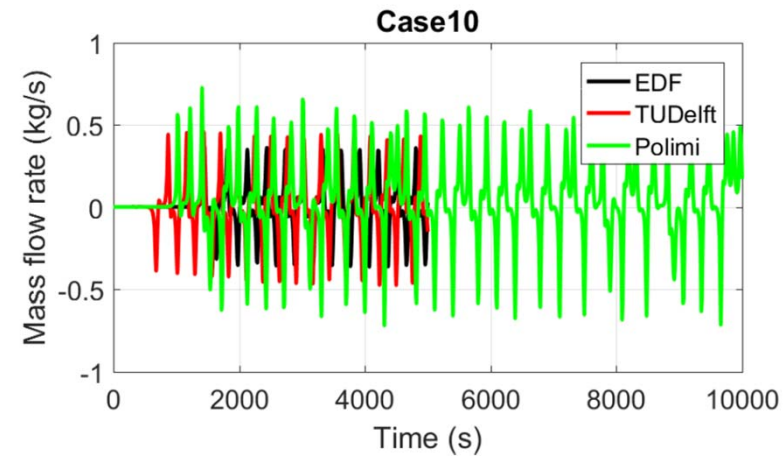
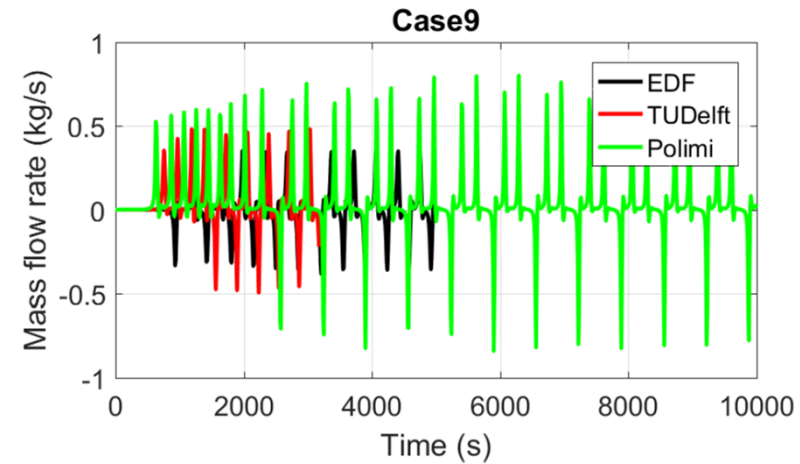
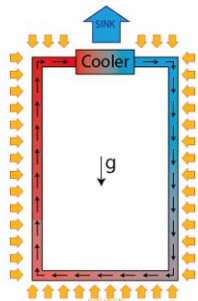

WP5: Chemical processing

- ▶ Interaction chemical plant and nuclear reactor (activity coefficients, extraction efficiencies \leftrightarrow elemental inventory)
- ▶ Experimental validation of reductive extraction process
- ▶ Evaluation of radioactive and toxic gas streams
- ▶ Evaluation of solid and fluid product streams
- ▶ Design requirements for shielding, hold-up tanks sizing, etc.
- ▶ Safety assessment (recriticality, shielding, ...)
- ▶ Evaluation of liners to the reactor vessel (ZrO_2 coatings to Ni-based alloys)

WP6: Dissemination/exploitation

- ▶ Education and training of students
- ▶ Exchange of students
- ▶ Connection to strategic stakeholders
- ▶ MSR School for students (summer 2017)
- ▶ MSR Bootcamp with NuSTEM (summer 2019)
- ▶ Workshop stakeholders (summer 2019)
- ▶ ...





Overview and objectives

Oct 2019 - Sep 2023

SAMOSAFER participants

List of Participants			
Number	Organisation	Institution	Country
1 (Coord)	Technische Universiteit Delft (TU Delft)	University	The Netherlands
2	Centre National de la Recherche Scientifique (CNRS)	R&D/University	France
3	JRC - Joint Research Centre- European Commission (JRC)	R&D	Germany
4	Institut de Radioprotection et de Sûreté Nucléaire (IRSN)	TSO	France
5	Framatome (Framatome)	Industry	France
6	Commissariat a l'Energie Atomique et aux Energies Alternatives (CEA)	R&D	France
7	Nuclear Research and Consultancy Group (NRG)	R&D/Industry	The Netherlands
8	Paul Scherrer Institute (PSI)	R&D	Switzerland
9	Karlsruher Institut für Technologie (KIT)	R&D	Germany
10	Politecnico di Milano (POLIMI)	University	Italy
11	Politecnico di Torino (POLITO)	University	Italy
12	Electricité de France (EDF)	Industry	France
13	Research Centre Řež (CV REZ)	R&D	Czech Republic
14	University of Ontario Institute of Technology (UOIT)	University	Canada

SAMOSAFER contents

- ▶ The goal of SAMOSAFER is to develop and demonstrate new safety barriers for more controlled behaviour of Molten Salt Reactors in transients and accidents, based on new simulation models and tools validated with experiments. The grand objective is to ensure that the MSR can comply with all expected regulations in 30 year time.

SAMOSAFER contents

1. Investigating the existing defence-in-depth safety approach to MSR.
2. Developing a rigorous and well-established simulation code suite through:
3. Developing experimental setups for the validation of simulation models:
4. Design and demonstration of barriers for severe accidents in MSR.
5. Update of the MSFR design with all improvements from these studies.
6. Attracting and educating students, postdoctoral researchers and trainees.
7. Develop and train a software user community.

Phenomena investigated

- ▶ Freezing of the fuel salt against cold walls and subsequent remelting;
- ▶ Internal heating of the salt causing lower natural circulation and local overheating;
- ▶ Overheating of the fuel salt in the core during transients and in the drain tanks;
- ▶ Effects of transients on the thermo-mechanical integrity of the primary circuit;
- ▶ Redistribution of the source term in the processing unit via gas bubbling, fluorination and chemical extraction leading to changes in chemistry and mobility of radionuclides.
- ▶ Thermo-chemical modelling to evaluate the fission products retention properties, and the effects of various products on the thermo-physical properties (melting point, heat capacity, vapour pressure, viscosity, thermal conductivity, etc);
- ▶ Radiation heat transfer to calculate accurately decay heat removal;
- ▶ Predictive reactor control strategies to reduce the number of draining events;
- ▶ Redox control of the fuel salt to avoid corrosion in the primary circuit;
- ▶ Reactor scaling effects on the safety of nuclear reactors in general;
- ▶ Uncertainty quantification methods based on non-intrusive PCE and ROM methods.

Facilities

- ▶ **DYNASTY:** This is a 10 meters high facility at POLIMI to study the flow dynamics of internally heated salts. Two versions exist: a single loop system and two connected loops. The latter setup simulates the primary salt circuit (core region) connected to the salt flow in the intermediate circuit. DYNASTY is fully instrumented and can be used to study decay heat removal from the core region by natural circulation. DYNASTY has been modified in the SAMOFAR project to fully meet the needs of the MSR;
- ▶ **ESPRESSO:** This is a new facility at TU Delft to investigate melting and solidification phenomena in conjunction with flow. Emphasis will be on local velocities in the fluid measured with LDA and PIV, and on the development and growth rate of the solid salt layer near the cooled surface;
- ▶ **High Flux Reactor:** This 40 MWth material testing reactor is being used to irradiate samples of fuel salt containing ThF_4 in LiF for 2 years. Analysis in the hot cell laboratories of NRG and at JRC-Karlsruhe, focusing on the fission product composition, redox potential, and the interactions between the fuel salt and the graphite crucibles and between the fuel salt and metal encapsulation;
- ▶ **SWATH-S:** This is a facility at CNRS consisting of two vessels of which one is filled with liquid salt (FLiNaK). By pressure the salt can flow from one vessel to the other, thereby passing an experimental station in a glovebox. The experimental station can be adopted to the needs of the experiments, like the measurement of flow and temperature profiles of the salt in turbulent and laminar conditions, and freezing phenomena of the salt against cold walls.

Education and Training

- ▶ Education of bachelor, master and PHD students
- ▶ Student mobility scheme
- ▶ Webinars on MSR neutronics, thermal-hydraulics, chemistry, experiments, ...
- ▶ Basic principle software simulator for training
- ▶ Summer school September 2021
- ▶ Young-MSR conference
- ▶ Stakeholder workshop 2023



**Collaboration
and joint efforts
appreciated**