

OSU Thermal Hydraulic Loops

Xiaodong Sun

Nuclear Engineering Program
Department of Mechanical and Aerospace Engineering
The Ohio State University

October 5, 2016



THE OHIO STATE UNIVERSITY



Acknowledgements

- This research is being performed using funding received from the DOE Office of Nuclear Energy's Nuclear Energy University Programs
- Collaborators:
 - Thomas Blue (OSU-emeritus)
 - Richard Christensen (OSU-emeritus)
 - Srinivas Garimella (Georgia Tech)
 - David Holcomb (ORNL)
 - Qiuping Lv (OSU, now at ANL)
 - Farzad Rahnema (Georgia Tech)
 - Piyush Sabharwall (INL)
 - Dane Wilson (ORNL)
 - Grady Yoder (ORNL)

Outline

- Status of Thermal Hydraulic Loops for DRACS Testing
 - Low-temperature DRACS test facility (LTDF)
 - High-temperature DRACS test facility (HTDF)
- Additional Test Loops/Facilities
 - Component testing
 - Heat exchanger testing
 - Corrosion screening testing: SS 316H in FLiNaK
 - Reduced-scale tritium removal testing

Direct Reactor Auxiliary Cooling System (DRACS)

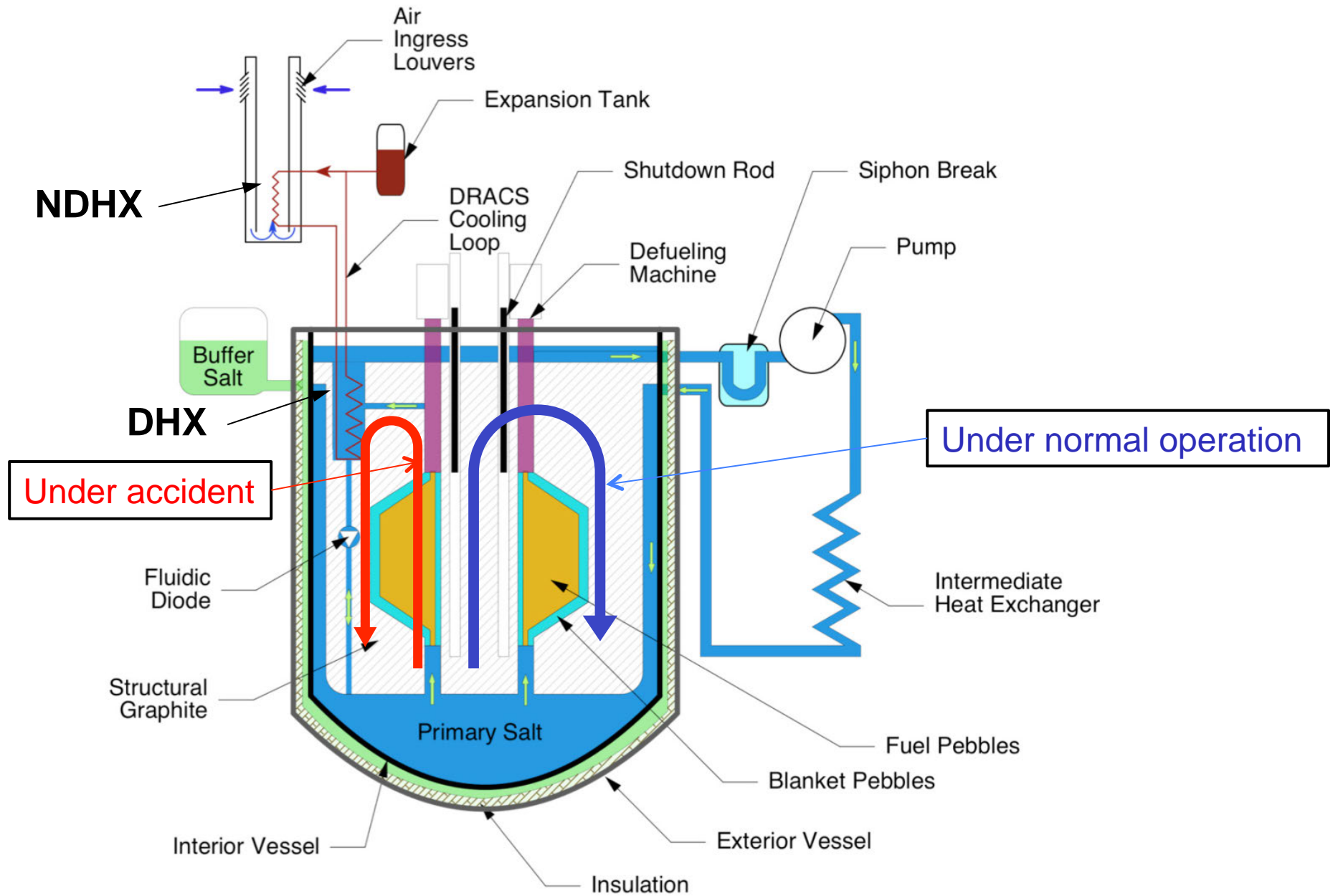

Low-Temperature DRACS Test Facility (LTDF)

- To understand coupling and interactions of three natural circulation/convection loops
- To provide experience for construction and operation of a high-temperature salt test facility
- Construction and testing: Completed
 - DRACS startup test
 - Pump trip tests without/with IHX

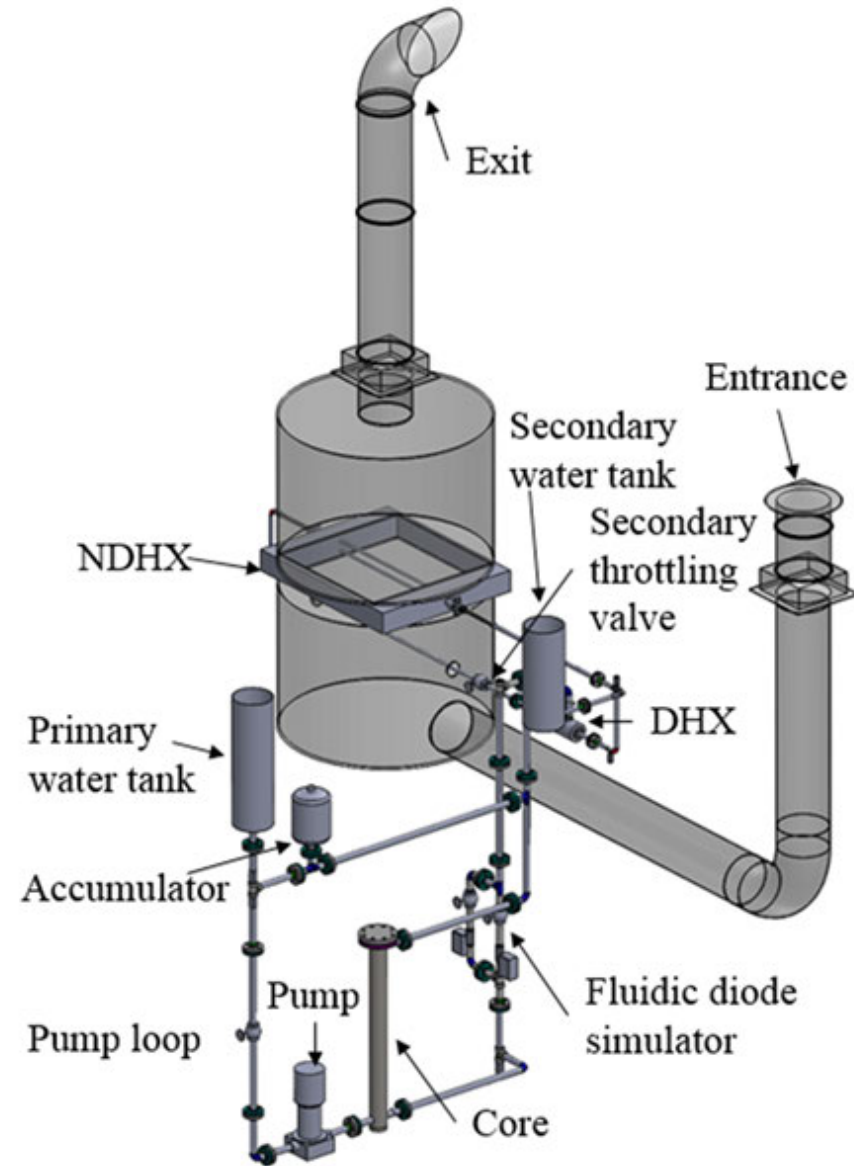

	Primary water (1.0 MPa)	Secondary water (0.1 MPa)	Air
T_{hot} (°C)	76.5	65.2	40
T_{cold} (°C)	63.7	34.8	20
\dot{m} (kg/s)	0.038	0.016	0.102
Loop Height (m)	1.71	0.42	3.43

LTDF (Cont'd)



LTDF: Two-Dimensional As-built Drawing

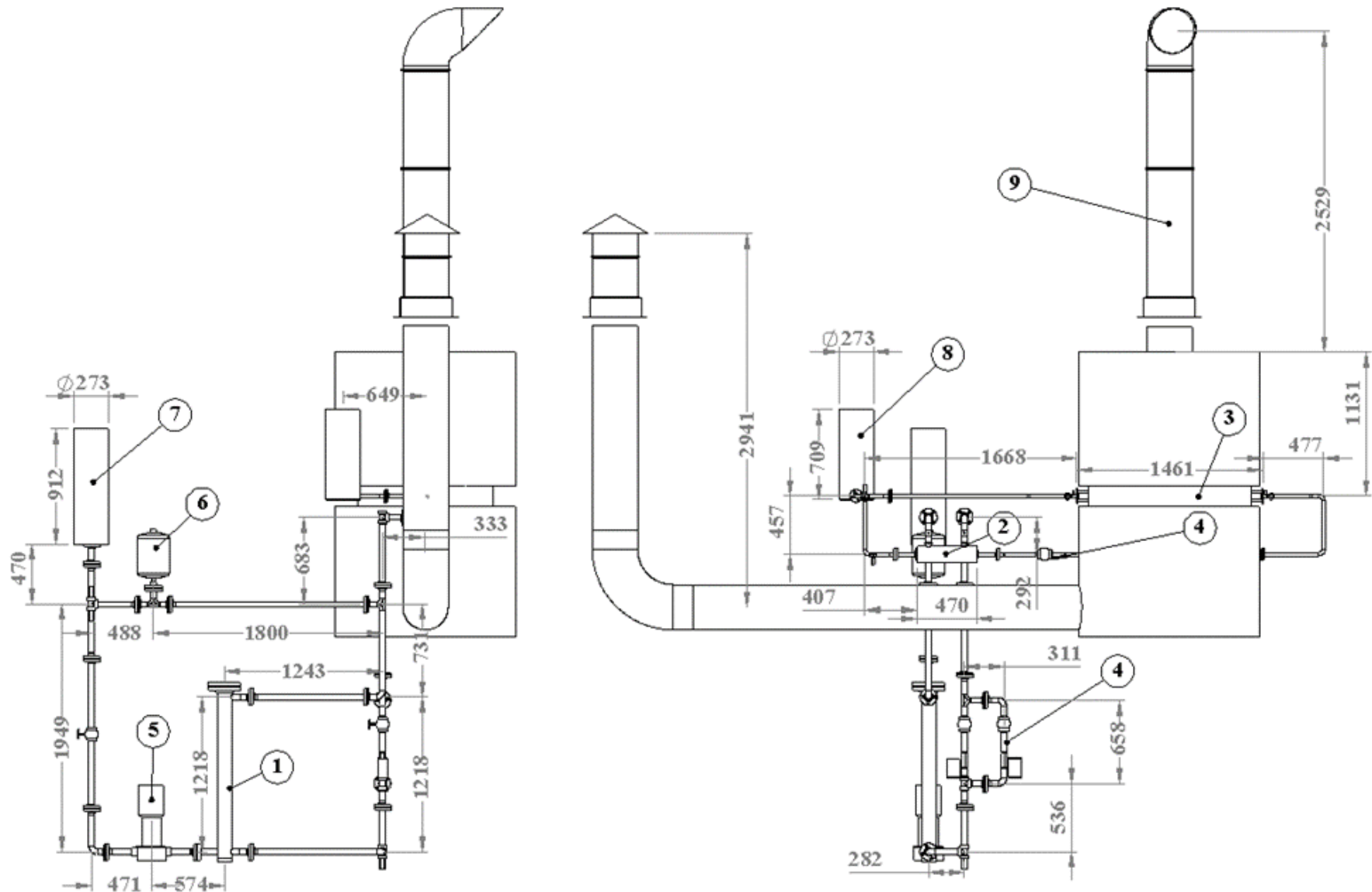

1	2	3	4	5	6	7	8	9
Core	DHX	NDHX	Secondary throttling valve	Pump	Accumulator	Primary water tank	Secondary water tank	Chimney

High-Temperature DRACS Test Facility (HTDF)

- Primary and secondary salts: FLiNaK
- Core: Simulated by seven cartridge heaters with special sheath to match fuel heat conduction time (Max.: 70 kW)
- Pump: 5-hp cantilever sump pump from Nagle
- Fluidic diode: Vortex diode
- Fully instrumented: Clamp-on ultrasonic flow meters (Flexim); N-type thermocouples (Omega); level measurement (Delta Controls); in-house solution for the differential pressure measurement
- Construction completed, salt being prepared

	Primary Fluid (FLiNaK)	Secondary Fluid (KF and ZrF ₄)	Air
T_{hot} (°C)	722	666	110
T_{cold} (°C)	678	590	40
\dot{m} (kg/s)	0.120	0.127	0.142
Loop Height (m)	1.14	1.08	3.43

HTDF (Cont'd)

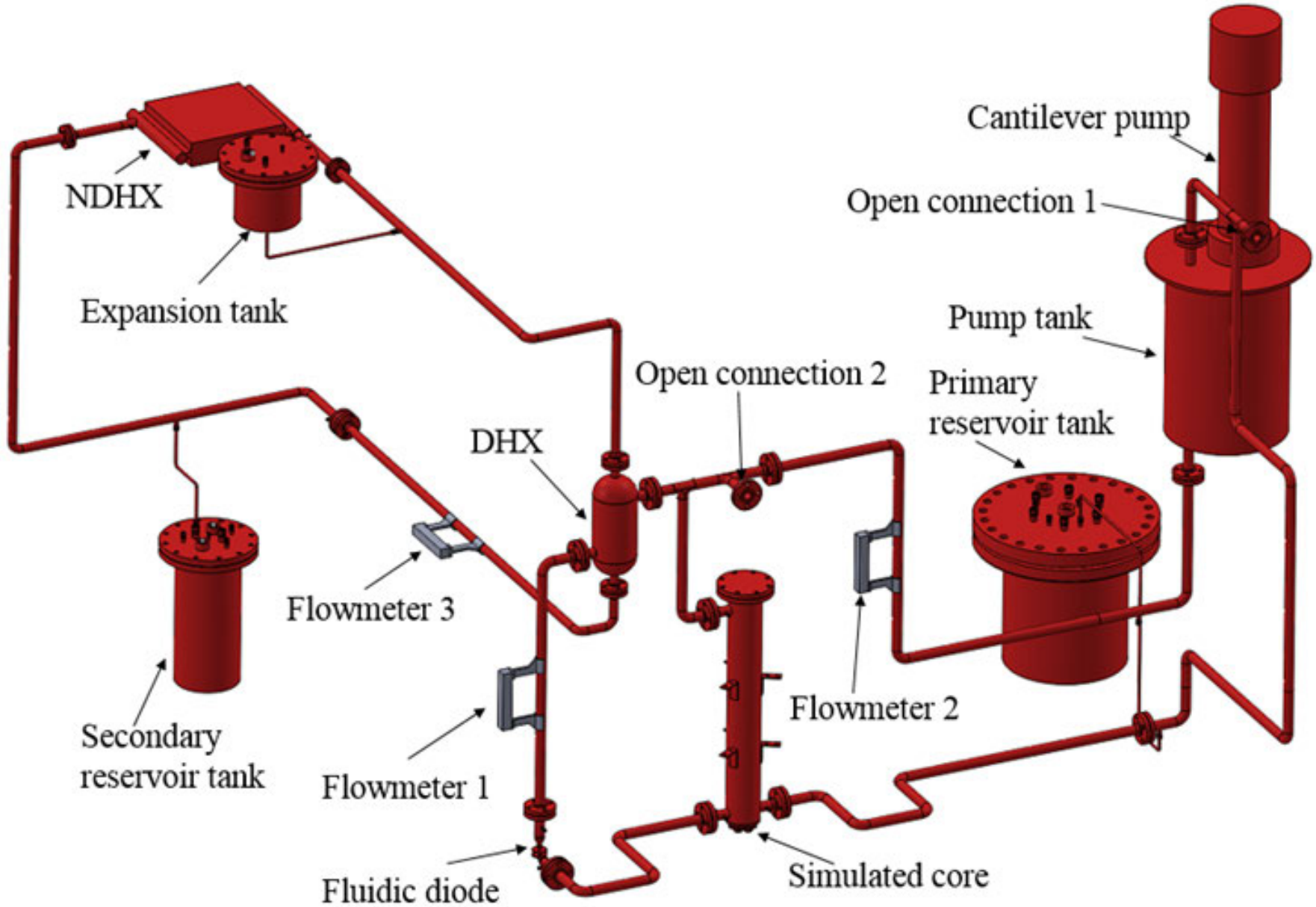

HTDF (Cont'd)



LTDF and HTDF Models in RELAP5

- RELAP5/SCDAPSIM/MOD 4.0
 - Selected for thermal hydraulic system-level code V&V
 - Salt property implementation
- RELAP5 models of LTDF and HTDF
 - Working fluid in LTDF: water, water, and air
 - Working fluid in HTDF: FLiNaK, KF-ZrF₄, and air
- Heat loss considered: Piping, flanges, and insulation

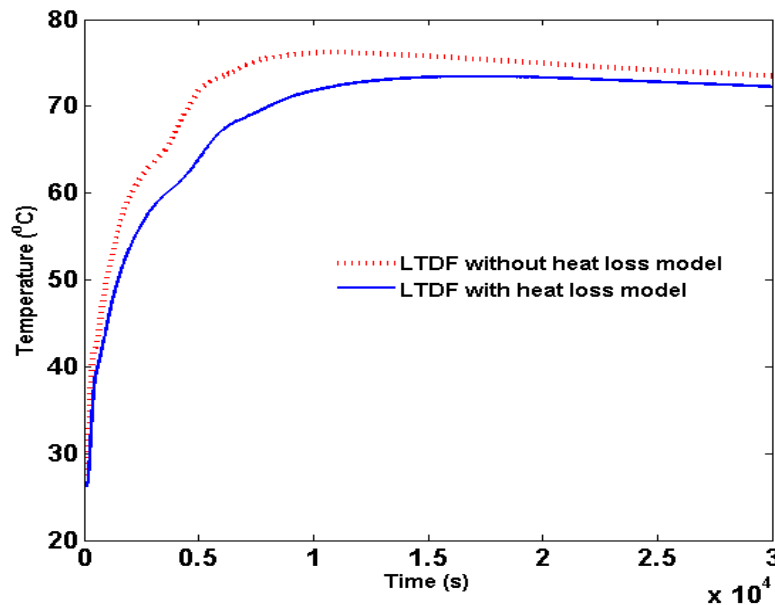

Comparison of with and without heat loss model

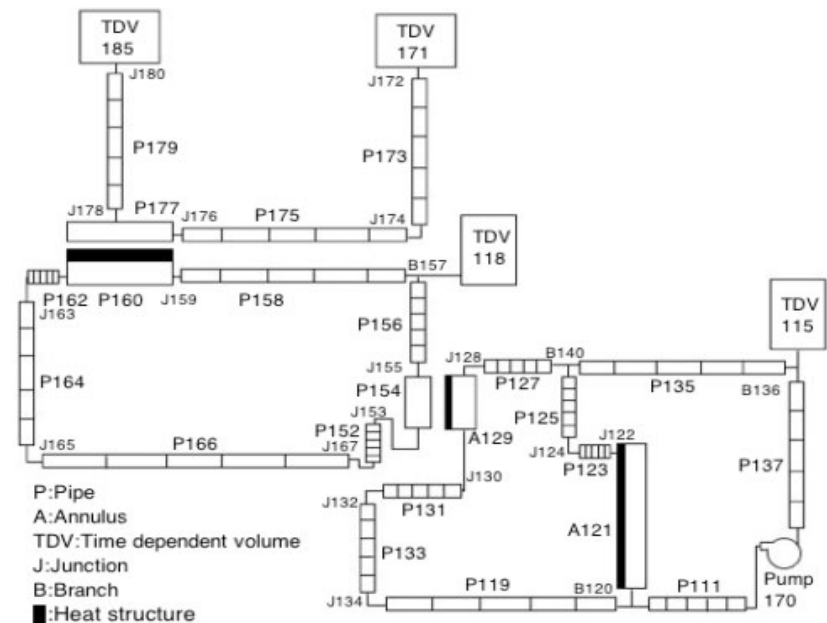

HTDF model in RELPA5

LTDF Benchmark Study

- RELAP5 simulation results against LTDF experimental data
 - DRACS startup scenario
 - Pump trip scenario

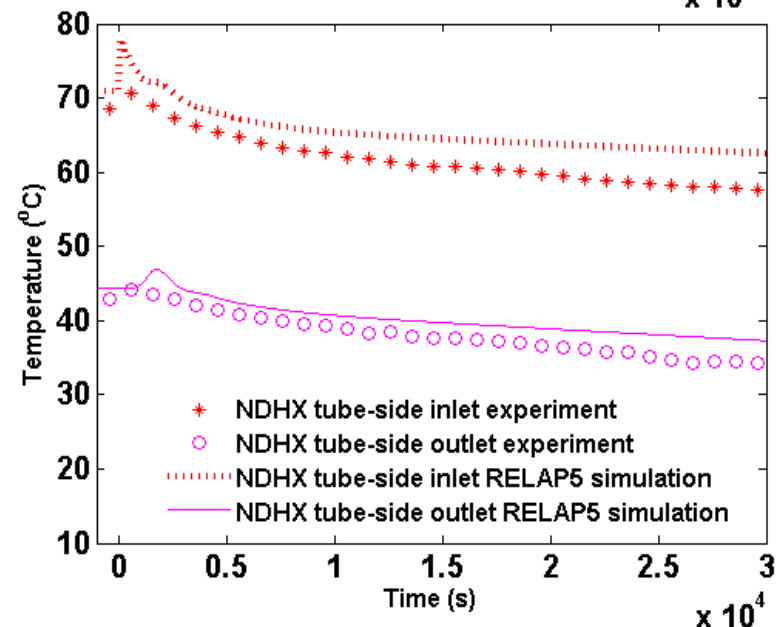
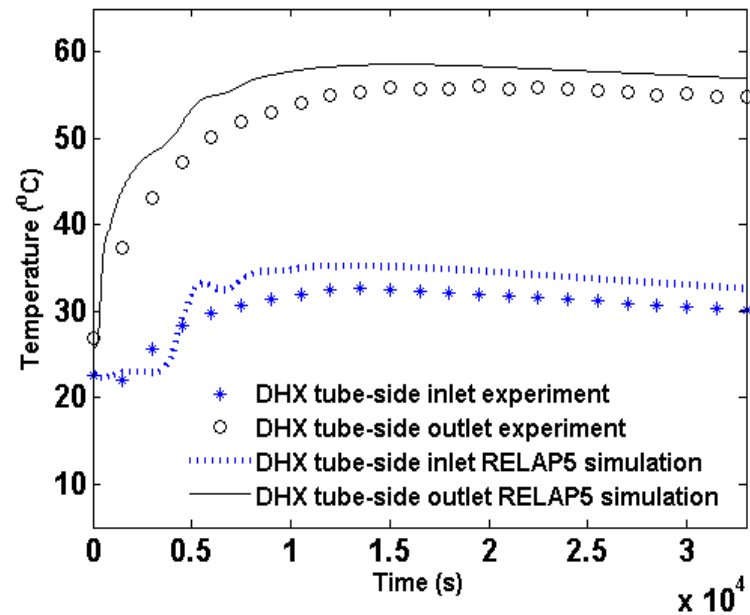
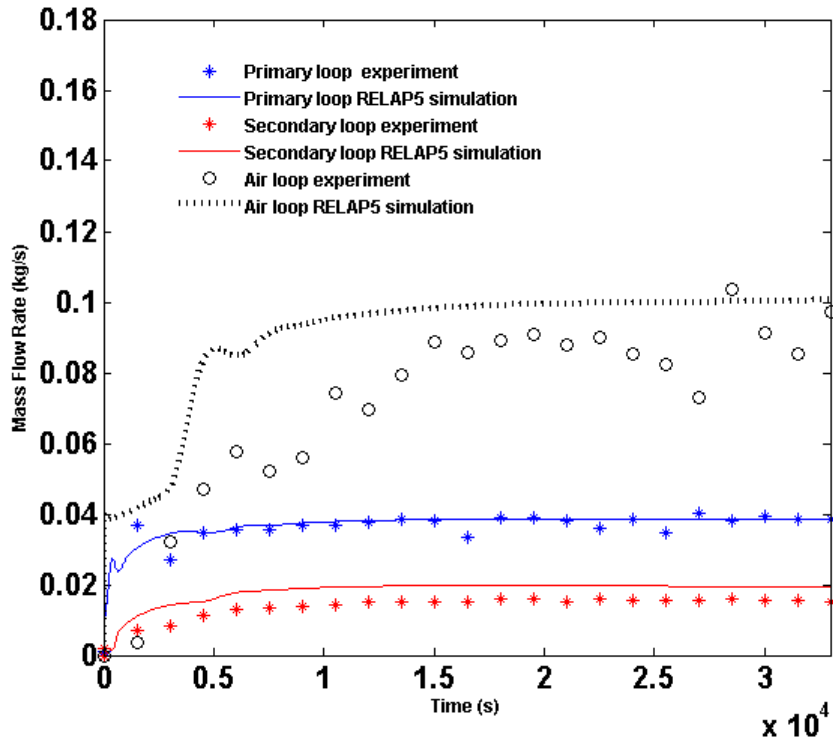

HTDF Simulation Results

- Thermodynamic and transport properties of molten salts (FLiBe, FLiNaK, and KF-ZrF₄) have been implemented into RELAP5
- RELAP5 transient analyses
 - DRACS startup scenario
 - Pump trip scenario
- Benchmark study to be performed when experimental data become available

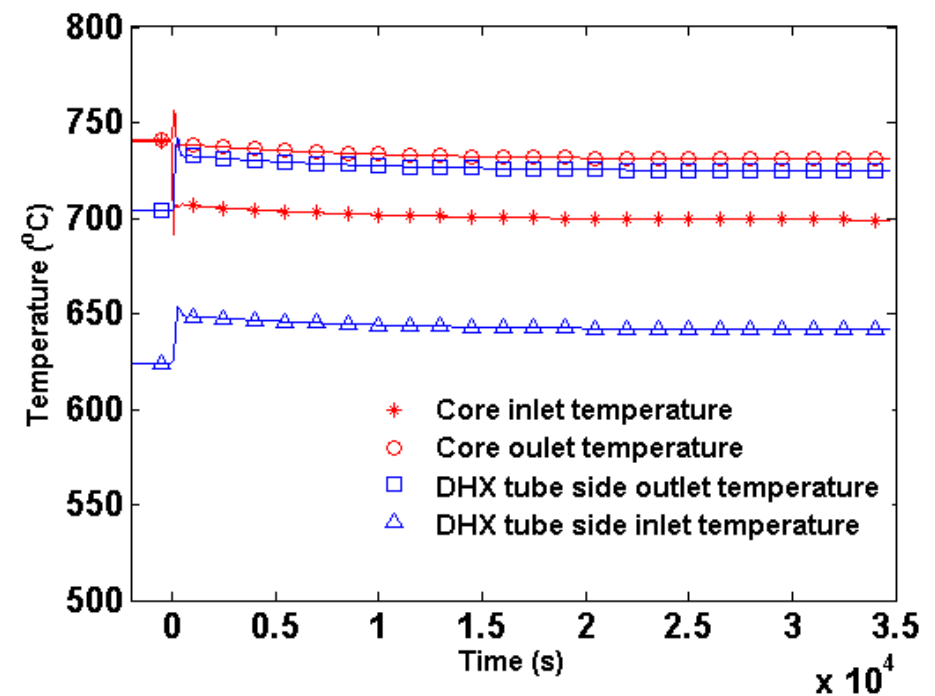
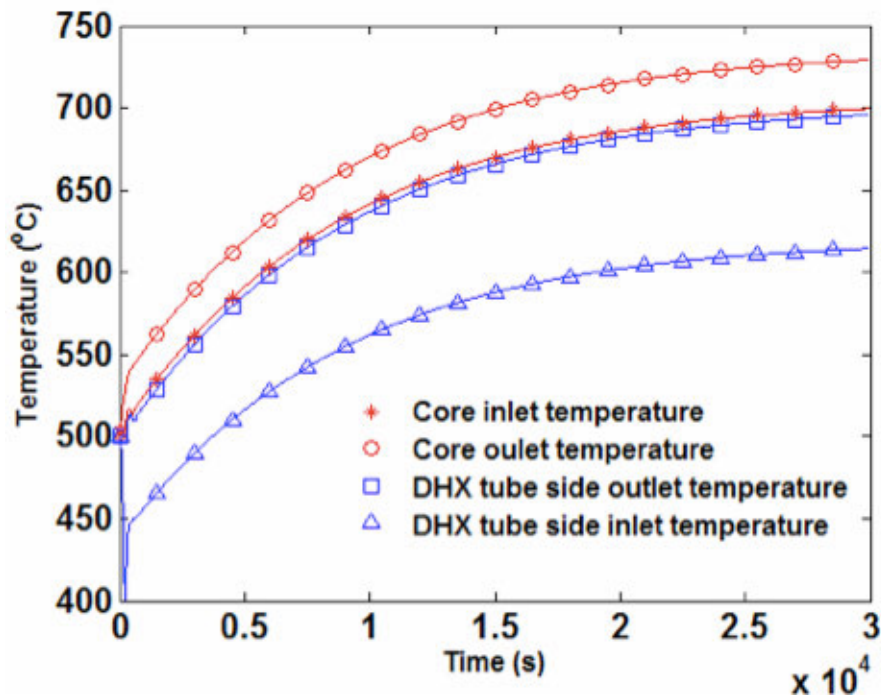

Salt Processing

- Preparing salt mixture
 - Further dehydrate the constituent salts at a controlled temperature (~150 to 200 °C)
 - Weigh and mix the salts in a controlled environment (glove box)
- FLiNaK melting point measurement
 - A flat-temperature stage corresponding to salt freezing
 - Melting point of 458.7 °C (average over 4500 - 5500 s)

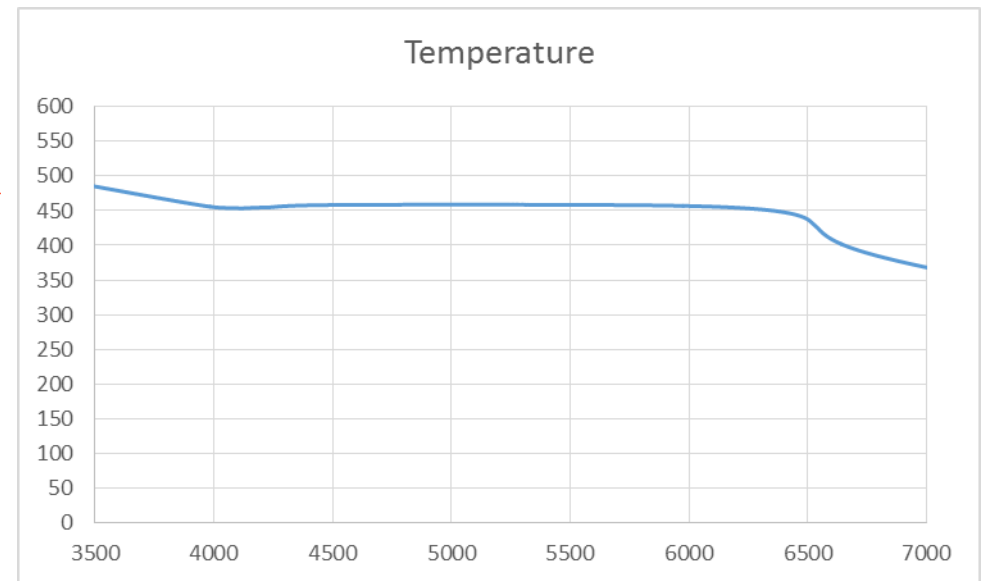
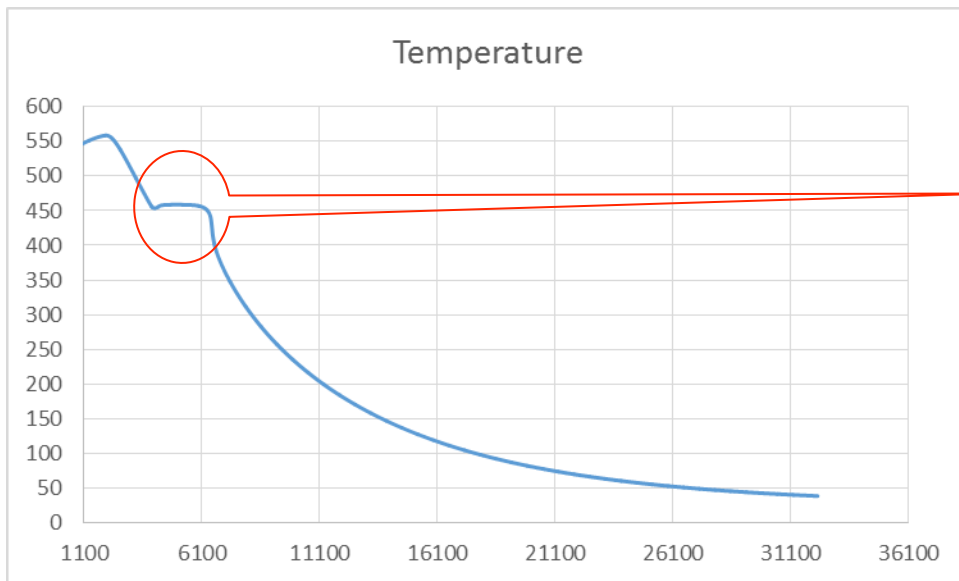

Salt Purification and Component Testing

- Filtering molten salt
- Testing valves
- Benchmarking ultrasonic flow meters under high-temperature liquid salt conditions
- Calibrating level sensors
- Testing differential pressure measurement method

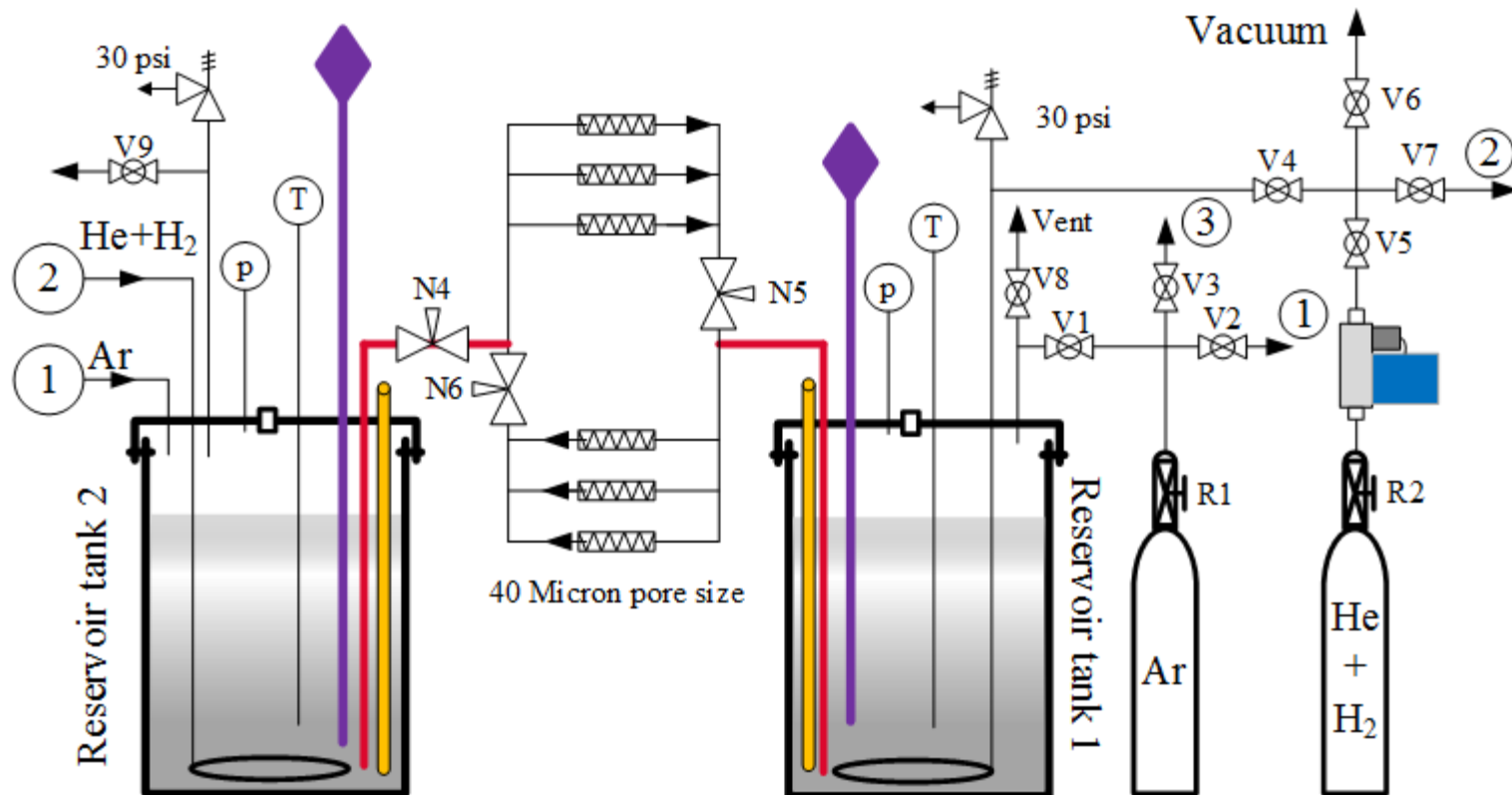

Heat Exchanger Testing

- Additional components are being added to the HTDF to facilitate HX testing under salt-salt and salt-air conditions

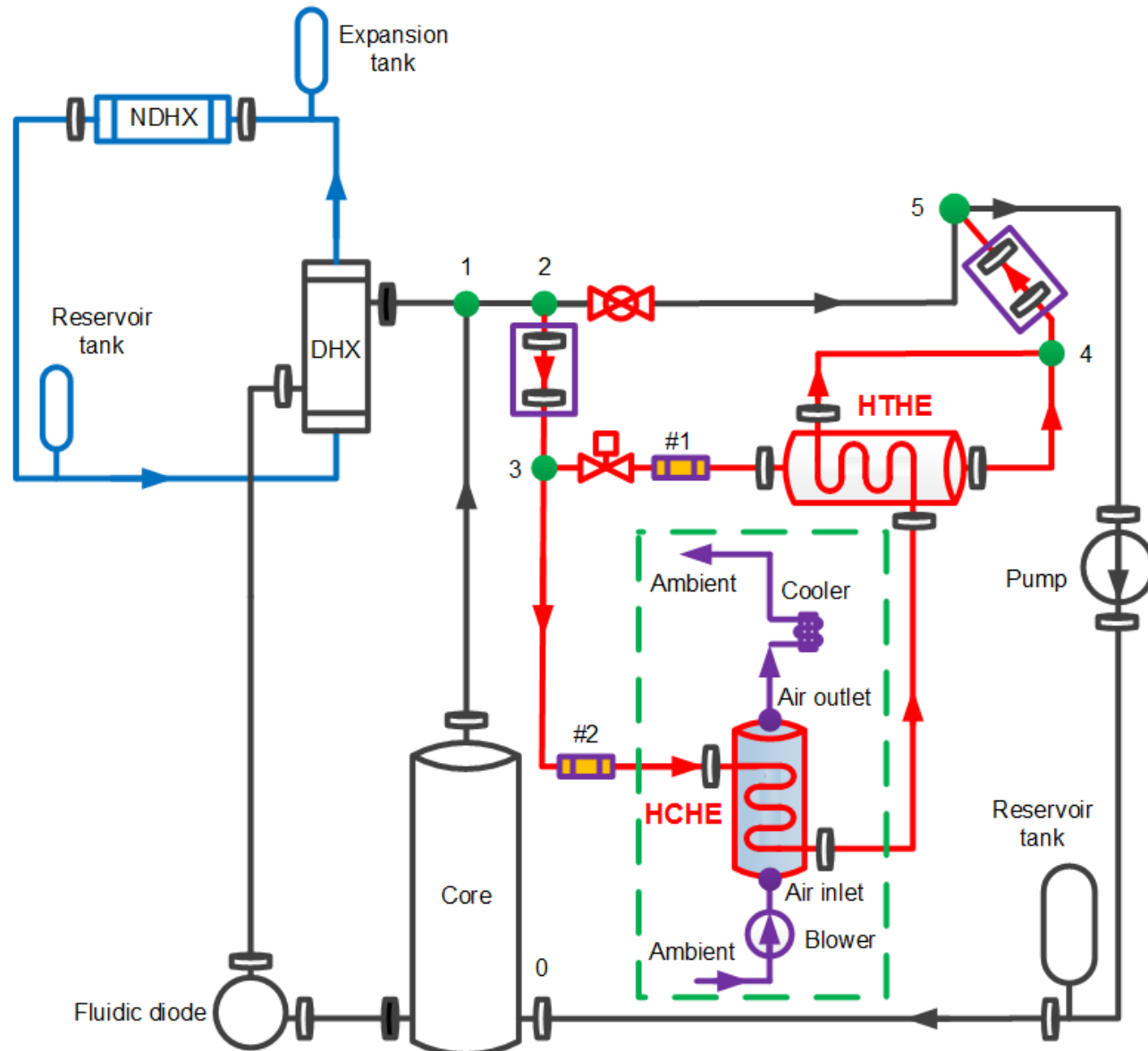

Corrosion Screening Testing

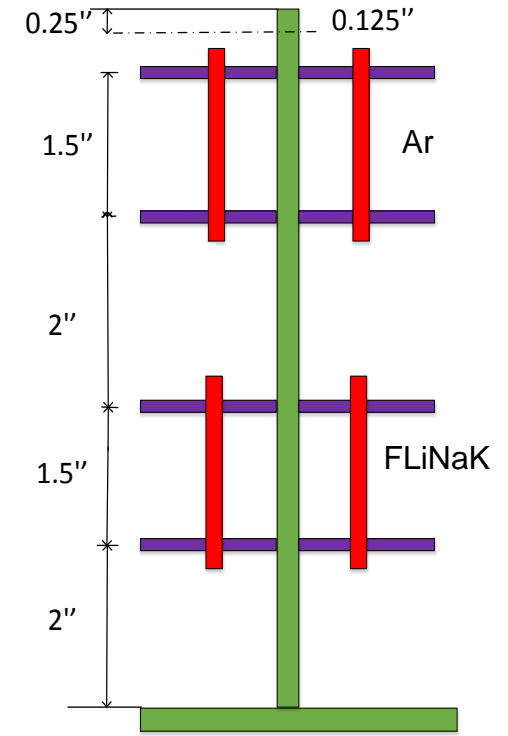
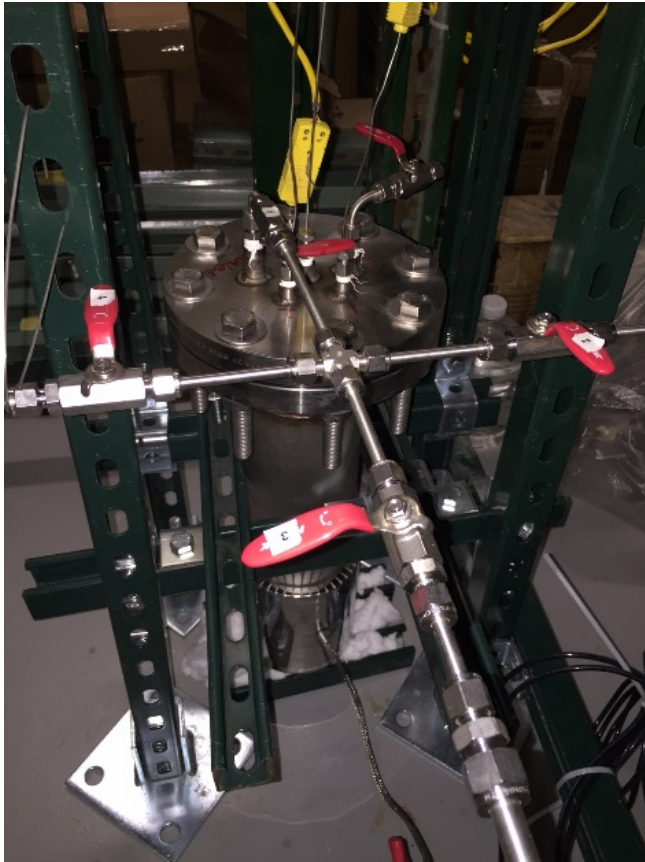

Operating Condition:

- Salt: FLiNaK
- Cover gas: Ar
- Temperature: 722 °C
- Time: 103 hrs
- Test specimen: SS 316H

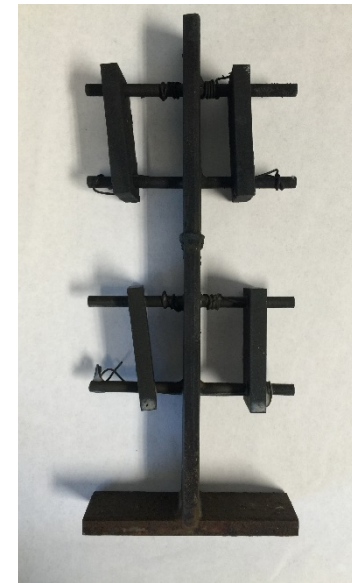
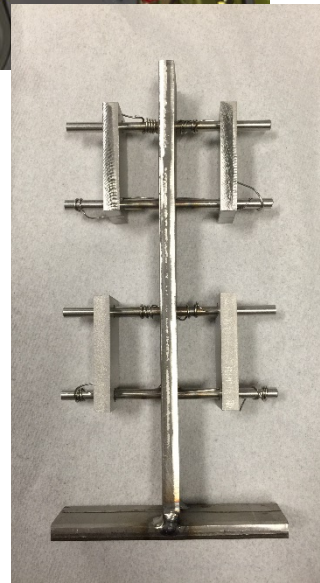

Corrosion Screening Testing (Cont'd)



Ultrasonic cleaner

Cleaning

- $\text{Al}(\text{NO}_3)_3$: 1 mol/L
- Distilled water

Corrosion Rate

A: 3.12 mg/cm²-d B: 3.07 mg/cm²-d
C: 2.87 mg/cm²-d D: 2.88 mg/cm²-d

A B C D

Before testing

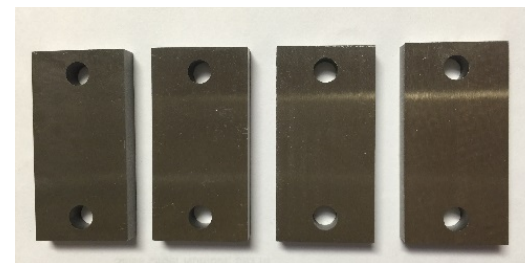

Before cleaning

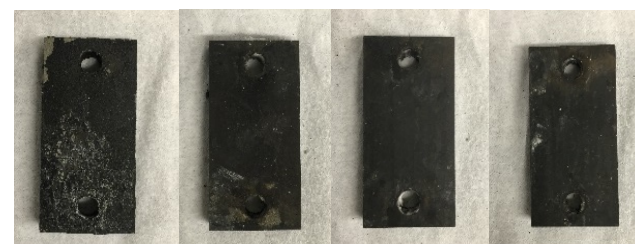

After cleaning



Corrosion Screening Test (Cont'd)

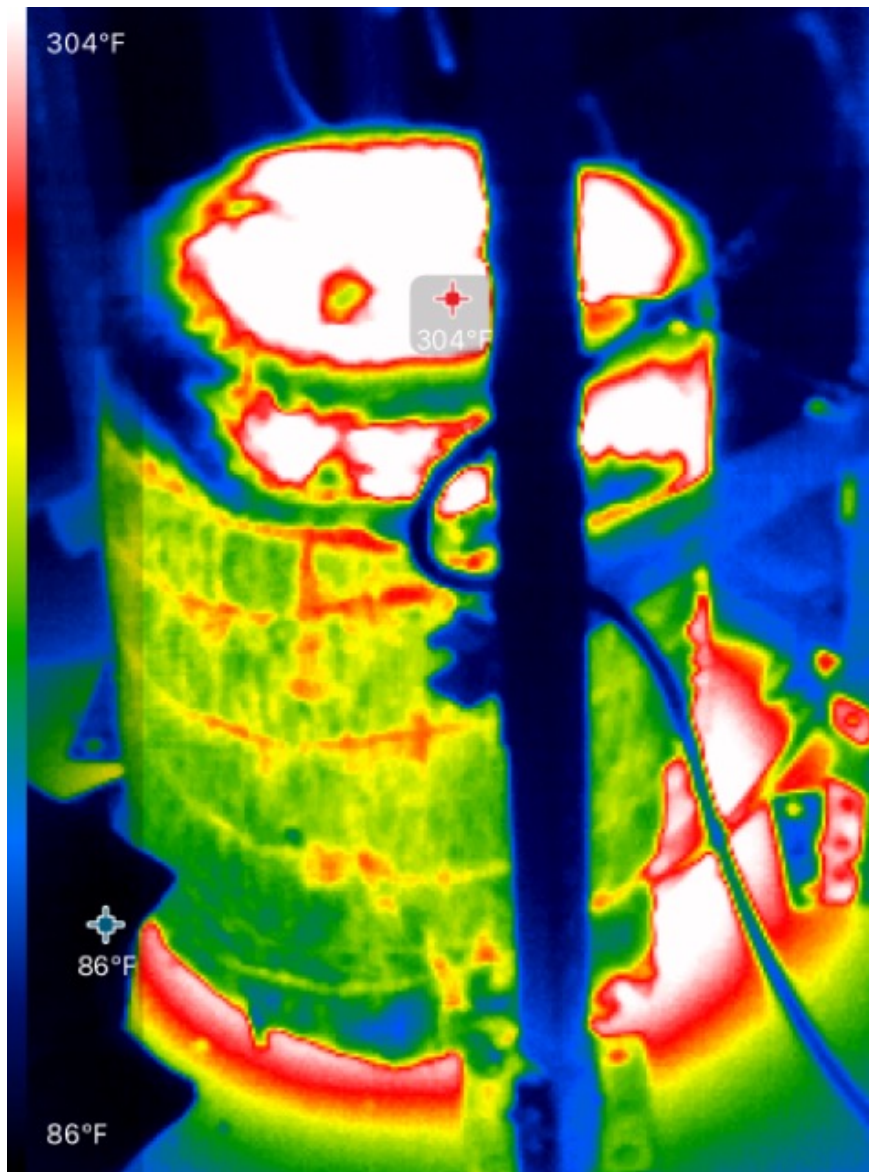

Reduced-scale Tritium Removal Testing

Back to main loop

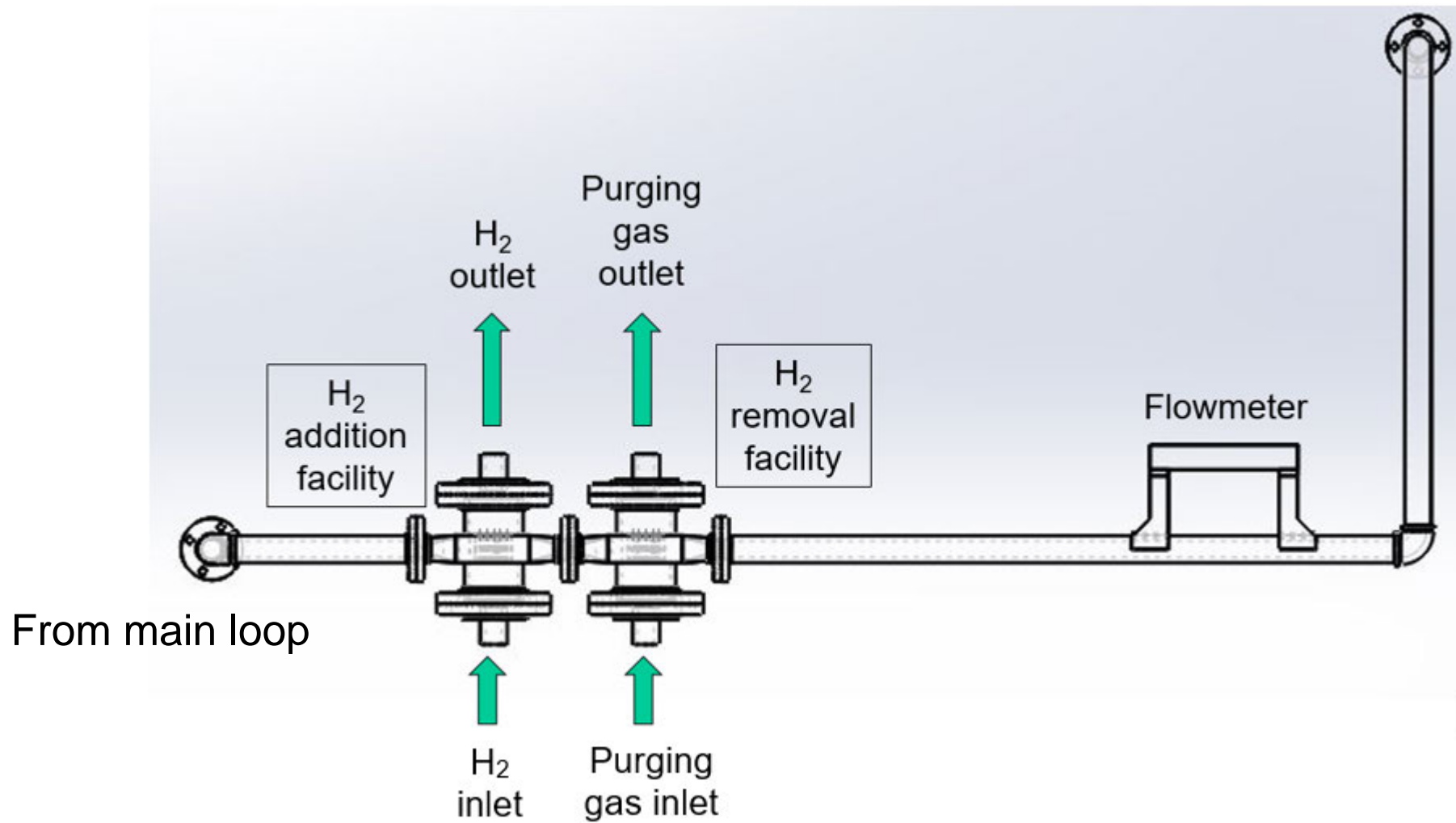

Reduced-scale Tritium Removal Testing (Cont'd)

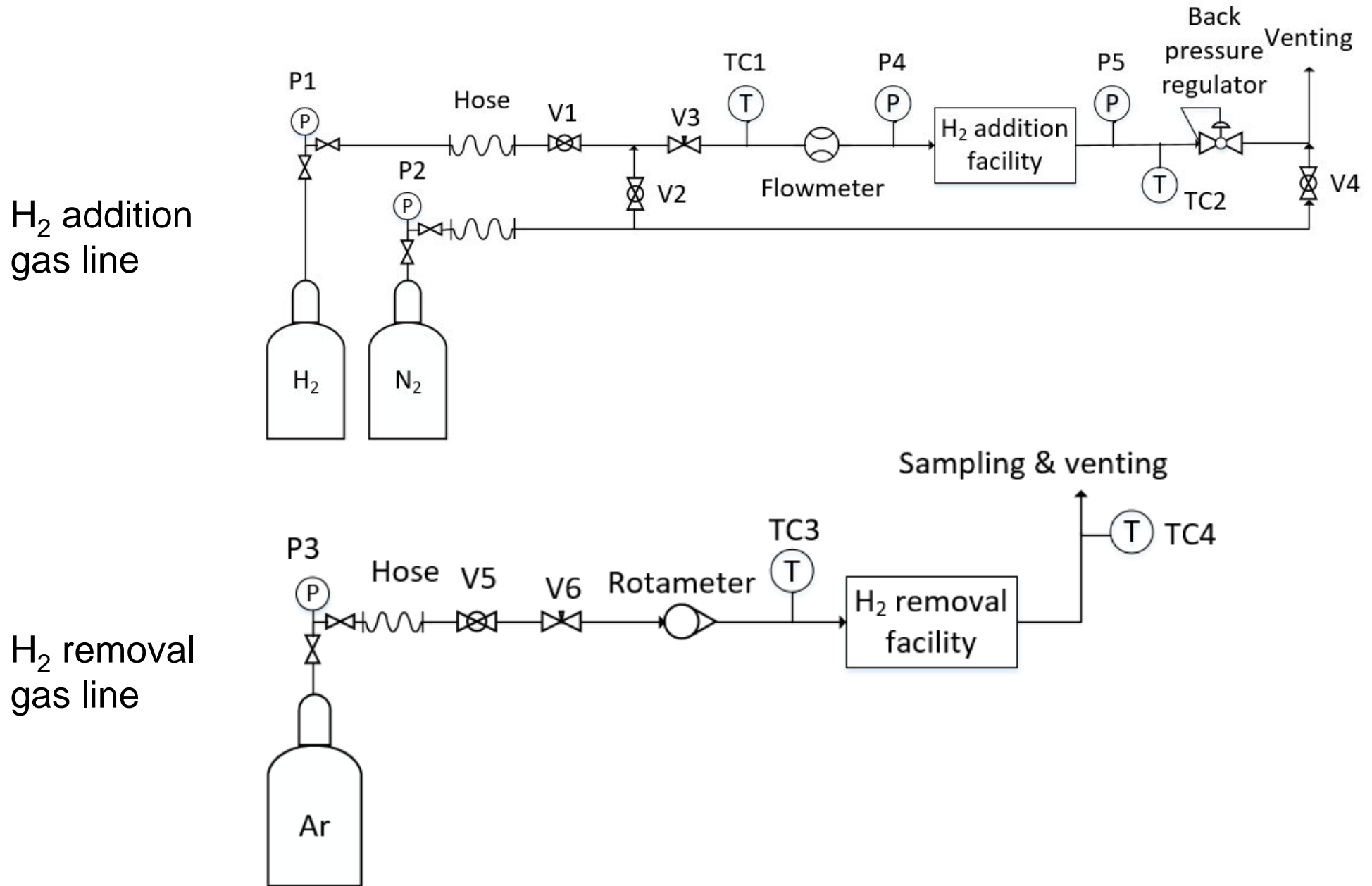

Reduced-Scale Tritium Removal Testing (Cont'd)

